

# 60cm Electric Double Oven

## DOUBLE OVEN

PRODUCT CODE: **EO8060DX**



eurocooking



### FEATURES:

- + Top Oven 4 multi-functions
- + Main Oven 8 multi-functions
- + Timer touch Clock Function control
- + Cavity Cooling System
- + Triple-glazed removable doors
- + Full inner glass on both doors
- + Stylish black / stainless steel finish

**3**  
YEARS  
Warranty

### OVEN MULTI-FUNCTIONS:



#### CONVENTIONAL

This method of cooking provides traditional cooking with heat from the top and lower elements. Particularly suitable for traditional roasting and baking on the centre shelf only.



#### FULL GRILL

Full grill is the perfect option for quick grilling. Toast your favourite meals or finish off the tops of your recipes.



#### BOTTOM ELEMENT

Great for pizza cooking, the bottom element creates the perfect cooking function for base cooked food.



#### TOP ELEMENT

Grill or toast enough of those favourite after school snacks to feed an army with the top element function.



#### DEFROST

In defrost mode, no heating elements are used. Only the fan is activated to circulate air inside the oven for defrosting. It defrosts food up to 30% faster than traditional methods.



#### OVEN LIGHT

The oven light will automatically turn on once any function is selected, helps to monitor the progress of your cooking.



#### FAN FORCED COOKING

For the ultimate roast or perfect batch of pastries. The element surrounding the fan delivers even heat for even cooking results, approx. 160°C - 180°C is recommended.



#### FAN GRILL

This function is perfect for fish, chicken Fillets or meat Cutlets. This Combination is exceptional for cooking meats such as poultry, game and roasts, making them crispy on the outside and tender in the middle.



#### HALF GRILL

Half grilling allows you to toast/brown all your favourite recipes in a smaller area.



#### FAN & BOTTOM ELEMENT

Great for pizza cooking, the fan and bottom element creates the perfect cooking function for base cooked food.

### SPECIFICATIONS:

<b>Electrical Requirements</b>	This oven requires 22 amps and needs a dedicated circuit from the socket to the main switchboard. For more information please refer to a qualified electrician.
<b>Power Consumption</b>	220-240v - 50Hz - 4.36Kw-5.19Kw
<b>Top Oven Volume Capacity</b>	40 litres (gross) - 38 litres ( net )
<b>Bottom Oven Volume Capacity</b>	61 litres (gross) - 56 litres ( net )
<b>Weight</b>	57.0kg (gross) - 53.0kg (net)

### PRODUCT DIMENSIONS:

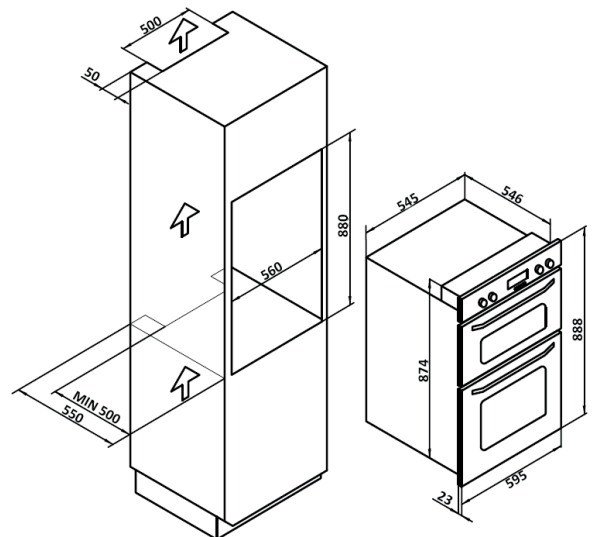

### CLEANING AND MAINTENANCE

Easy clean AAA grade enamel interior.  
Clean stainless steel using only recommended stainless steel cleaning products. No abrasives, corrosive detergents, bleaches or acids not required for cleaning the oven.